

Product Description
Safety Instructions
Operating Instructions
for
BINKS
Airless Model HP 6/34

These operating instructions are part of the equipment. Please read and follow all instructions and safety precautions before using the equipment. Disregarding can causes injuries on people and/or damages on the unit.

ITW Finishing Systems and Products

Ringwood Road, Bournemouth BH11 9LH, England
Phone +44 (0) 1202 / 571111 Telefax +44 (0) 1202 / 581940
Internet www.itwifeuro.com

Correspondance address:

ITW Oberflächentechnik GmbH & Co.

Justus-von-Liebig-Straße 31, 63128 Dietzenbach, Deutschland
Telefon +49 (0) 6074 / 403-1 Telefax +49 (0) 6074 / 403-281
Internet www.itwifeuro.com

Correspondance address:

ITW Surfaces et Finitions

163-171 Avenue des auréats BP 1453, 26014 Valence Cedex France
Téléphone +33 (0) 4 7575 2700 Fax +33 (0) 4 7575 2799
Internet www.itwifeuro.com



TABLE OF CONTENTS

| | |
|---|----|
| 1. DESIGNATED USE..... | 3 |
| 2. BRIEF DESCRIPTION | 4 |
| 3. TECHNICAL DATA | 8 |
| 4. SAFETY | 9 |
| 4.1 Principle of operation; intended use | 9 |
| 4.2 Safe working conditions..... | 9 |
| 4.3 Particular danger spots | 11 |
| 5. START UP AND OPERATION | 12 |
| 5.1 Grounding the BINKS airless pump..... | 12 |
| 5.2 Preparing to start up the BINKS airless pump..... | 12 |
| 5.3 Rinsing the BINKS airless pump..... | 13 |
| 5.4 Preparing and adjusting the spray material | 14 |
| 5.5 Start-up | 14 |
| 5.6 Work stoppages | 15 |
| 6. SHUT-DOWN..... | 16 |
| 7. CLEANING YOUR BINKS UNIT | 16 |
| 8. MALFUNCTIONS, POSSIBLE CAUSES AND REMEDIAL MEASURES..... | 17 |
| 8.1 Compressed air supply unit | 17 |
| 8.2 Pneumatic drive and control system unit..... | 17 |
| 8.3 Spray material pump unit | 19 |
| 8.4 Suction system unit | 19 |
| 9. INSTRUCTION MANUAL..... | 20 |
| 10. COMPULSORY TESTING | 20 |
| 11. TEST DOCUMENTS | 21 |
| 12. SPARE PARTS LISTS | 22 |
| 13. RECOMMENDED GUN | 43 |
| 14. EC DECLARATION OF CONFORMITY..... | 44 |
| 15. WARRANTY STATEMENT | 45 |

1. DESIGNATED USE

BINKS airless pumps are used exclusively to output and apply spray material. Any materials can be sprayed, if they are approved by spray material manufacturers for use with airless spraying equipment. These include:

- Water-thinnable lacquers and paints
- Solvent-based lacquers and paints
- Base paints and primers
- Micaceous iron ore
- Zinc-rich paints
- Epoxy and polyurethane paints
- Oils
- Liquid synthetic materials
- Wax-based underbody sealant materials
- Low-solvent and solvent-free spray material

Please observe the working guidelines and safety instructions supplied by the spray material manufacturer.



You should avoid using abrasive, granular spray material. Such spray material can cause heavy wear and tear on the valves and packing sets of the material pump, and on the nozzles used on the airless gun.

ATTENTION !

BEFORE STARTING UP PUMP FILL UP LUBRICATION FLUID

**FOR WATERBORNE PAINT: 0114-014871
FOR SOLVENT PAINT: 0114-009433**

2. BRIEF DESCRIPTION (FIGURE 1)

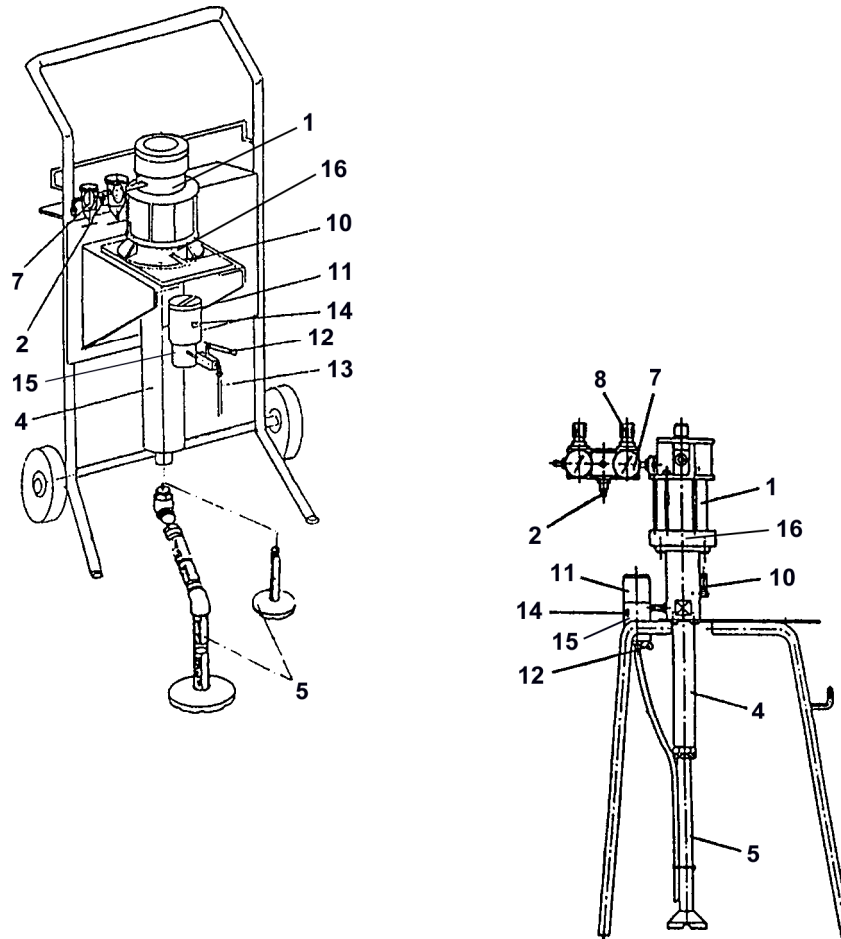

- | | | | |
|----|--|----|--|
| 1 | Pneumatic drive | 11 | High pressure filter |
| 2 | Compressed air supply connection piece | 12 | High pressure filter relief valve |
| 4 | Spray material pump | 13 | Return pipe |
| 5 | Suction system | 14 | Grounding terminal |
| 7 | Compressed air control valve | 15 | Spray material outlet connection piece |
| 8 | Pressure reducer | 16 | Grounding terminal (if used without HP-filter) |
| 10 | Release agent chamber | | |

Comments on figure 1

The pneumatic motor (1) drives the BINKS airless pump. An airflow controller in the pneumatic drive applies compressed air alternately to the pneumatic motor piston. This sets the butt plate moving upwards and downwards.

The pneumatic motor is flange-mounted directly to the spray material pump (4). A moving axle connects the pneumatic drive butt plate to the double piston of the spray material pump.

The ascending stroke of the double piston draws in the material through the suction system (5) and the foot valve of the material pump. At the same time, the material spray, which is already in the spray material pump above the double piston, is ejected through a check valve into the high pressure filter (11).

The descending stroke of the double piston closes the foot valve and the spray material which has been drawn in, is forced through a plunger valve into the space above the double piston. At the same time, the spray material which is already there is ejected into the high pressure filter.

If the airless gun take-off is not operative, counter pressure will build up in the spray material line. The pump will stop. Remove spray material from the airless gun and the BINKS airless pump will start up again.

The area of the motor piston is greater than the area of the material piston. This difference in area causes the pressure to intensify. With an area ratio of 60/1, for example, a working pressure of 1 bar at the pneumatic drive will be intensified to a working pressure of 60 bar at the spray material pump.

The lubrication chamber (10) physically separates the pneumatic drive from the material pump. The lubrication chamber is filled with lubricant (Order Code 0114-014871 for waterborne paint, Order Code 0114-009433 for solvent paint). The release agent cleans the double piston of the spray material pump and lubricates the packing and the moving axle.

The volume of air and thus the delivered volume of spray material is regulated by the working pressure at the compressed air control valve (7). The compressed air control valve is equipped with an excess pressure safety valve, which is triggered if the maximum working pressure at the pneumatic motor is exceeded.

The material pump can draw in spray material in two ways.

Direct suction:

This involves immersing the suction system in the spray material.

Suction through a flexible suction system:

This involves connecting the spray material pump to a flexible suction system. The free end of the suction system is inserted into the tank containing the spray material.

The extracted spray material is filtered through the high pressure filter (standard filter on HP 6/34: type 03 - order-no. 0110-009130), before being driven out through the spray hose and the airless gun. We recommend the following filter cartridges for the various types of spray material:

| Filter size | Nozzle | Spray material |
|-------------|---------------------|---------------------------------|
| M 200 | less than 0.3 mm | colourless lacquer |
| M 150 | greater than 0.3 mm | surfacers, filler, red lead |
| M 100 | greater than 0.3 mm | surfacers, filler, red lead |
| M 70 | greater than 0.5 mm | micaceous iron ore, red lead |
| M 50 | greater than 0.6 mm | emulsion, loaded spray material |



Do not use a filter cartridge for fibre-loaded spray material!

HD filter cartridges (overview)

| | | | |
|---------------|---|--|---|
| |  |  |  |
| Filter-type | 01 | 03 | 11 |
| Order-no. | 0114-013525 | 0110-009130 | 0114-011760 |
| Screen area | 29 cm ² | 84 cm ² | 118 cm ² |
| Core material | polyamide | stainless steel | polyamide |

Figure 2

Packings:

The lifetime and the maintenance rate of a pump depend crucially on the right packing. The packing for solvent and waterbased paint are different.

For the use of high viscosity or high corrosion materials we recommend high-strength packing. Depending on the field of application there are different packings for solvent and waterbased materials.

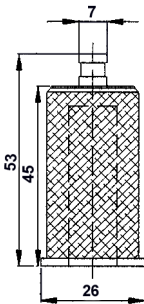
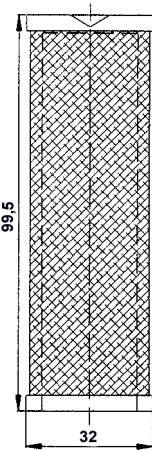
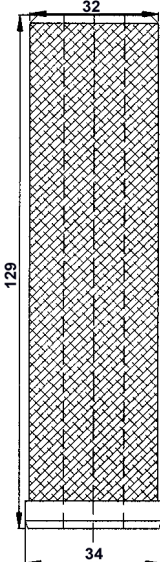
Standard packing:

Upper packing:

Mixed standard packing (for solvent paint materials) Part-no.: 0114-014477
Consisting of: PTFE/Leather packing

Standard packing (for waterborne paint materials) Part-no.: 0114-018924
Consisting of: PTFE packing

Lower packing:

Mixed standard packing (for solvent paint materials) Part-no.: 0114-014476
Consisting of: PTFE/Leather packing

Standard packing (for waterborne paint materials) Part-no.: 0114-018925
Consisting of: PTFE packing

Packings for high-strength and corrosion materials:

Upper packing:

Mixed high-strength packing (for solvent paint materials) Part-no.: 0114-016285
Consisting of: PTFE(high-strength)/Leather packing

High-strength packing (for waterborne paint materials) Part-no.: 0114-016283
Consisting of: PTFE(high-strength) packing

Lower packing:

Mixed high-strength packing (for solvent paint materials) Part-no.: 0114-016286
Consisting of: PTFE(high-strength)/Leather packing

High-strength packing (for waterborne paint materials) Part-no.: 0114-016284
Consisting of: PTFE(high-strength) packing

Note:

To the high-strength packings graphite is added to the PTFE. This improves the lubrication qualities. High strength packings are not recommended for bright finish paint. Graphite can change the colour of the finish paint.

If you need special packings without graphite admixture please contact your dealer.

Our pumps are supplied fitted work-sided with mixed packing for the application of solvent paint.

3. TECHNICAL DATA

| BINKS | | HP 6/34 |
|--------------------------|----------------------------|--|
| Theoretical transmission | | 34 : 1 |
| Air motor | Air inlet pressure | 8 bar |
| | Diameter cylinder | 105 mm |
| Material pump | Volume double stroke | 38 ccm |
| | Operating pressure max. | 272 bar |
| | Piston stroke | 75 mm |
| | Free flow capacity nominal | 2,3 ltr./min. |
| | Piston diameter D1 | 18 mm |
| | Piston diameter D2 | 25 mm |
| Connections | Air inlet | Stem for quick disconnection or R 3/8" (m) |
| | Air to gun (Aircombi only) | 90° connection for hose 8x6 or 1/4" NPS (m) |
| | Fluid outlet on HP-filter | 1/4" NPS (m) |
| Dimensions of bare pump | L x W x D in mm | 725 x 220 x 190 |

The nameplate on your outfit is attached to the spray material pump. Enter the data from the nameplate into figure 3. Have this information ready when you call customer service.

Figure 3

| ITW Finishing Systems and Products | |
|--|---|
| Ringwood Road, Bournemouth BH11 9LH, England | |
| Druckluft getriebene Kolbenpumpe | |
| Geräte-Typ | <input type="text"/> |
| | Packung PTFE <input type="checkbox"/> Leder/PTFE <input type="checkbox"/> |
| Herstell-Nr./Baujahr | <input type="text"/> |
| Fördermenge/Doppelhub | <input type="text"/> cm ³ Mat.Temp.max. <input type="text"/> °C |
| Materialüberdruck max. | <input type="text"/> bar Übersetzung <input type="text"/> :1 |
| Lufteingangsdruck max. | <input type="text"/> bar |

ITW Finishing Systems and Products
 Ringwood Road, Bournemouth BH11 9LH, England
 Phone +44 (0) 1202 / 571111 Telefax +44 (0) 1202 / 581940
 Internet www.itwifueuro.com

4. SAFETY

As well as the operating instructions and the applicable legal and other mandatory regulations relevant to accident prevention in the country of use and at the place of use, you must also observe the recognised special engineering regulations governing safe and professional working practices.

4.1 PRINCIPLE OF OPERATION; INTENDED USE

1. BINKS airless spraying equipment has been built to comply with state-of-the-art standards and recognised safety rules. Nevertheless, its use may constitute a risk to life and limb for the user or for third parties, or cause damage to the BINKS airless pump and other assets.
2. The BINKS airless pump must only be used in technically perfect condition in accordance with the regulations and the instructions set out in the operating instructions and only by safety-conscious persons fully aware of the risks involved. Any malfunctions, especially those affecting safety, must be rectified immediately. The spray material line must not be dragged across sharp-edged objects and must always be checked before use to ensure that it is in perfect condition.
3. BINKS airless pumps are designed exclusively for the designated use stated in Section 1. Using them for purposes other than those mentioned is considered contrary to the intended use. The manufacturer/supplier cannot be held liable for any damage resulting from such use. The user alone must bear the risk.
4. The manufacturer is not liable for any unauthorised modifications or repairs made to the BINKS airless pump.
5. In accordance with the professional association directives governing spray equipment, ZH 1/406, paint spraying equipment should be checked by experts on request, or at least every 12 months, to ensure that there is no risk involved in its continued operation. If the units are idle, the examination can be delayed until the next period of operation. The operator is obliged to register the equipment for testing and to keep written records of the results of such testing.

4.2 SAFE WORKING CONDITIONS

1. The requirements of the (German) accident prevention and safety regulation "Working with surface coating compounds" (VBG 23) and the (German) directives governing jet stream units (ZH 1/406) and static electricity (ZH 1/200) provided by the professional associations, must be observed.
2. Every person using a BINKS airless pump must have read and understood the operating instructions, in particular the chapter on "Safety".
3. If work is to be carried out in enclosed areas, effective, technical ventilation must be provided.
4. Use only those spray material lines and airless guns that are designed for use at the relevant maximum permitted working pressure of the spray material pump.
5. Be careful that there are no sources of ignition in the vicinity, for example, an open fire, sparks, glowing wires, hot surfaces, burning cigarettes, etc. There must be a distance of at

least 5 m between the spray jet outlet and any possible source of ignition (the spray mist is ignitable and there is a risk of fire or explosion).

6. The spray material leaves the nozzle under pressure. Do not direct the spray jet towards people or animals, as this could cause injuries. If the skin is broken and comes into contact with paint, lacquer or solvent, there is a risk of infection. Consult a doctor immediately to obtain professional, expert treatment. Tell the doctor which spray material or solvent is involved. Present the safety data sheet.
7. Be aware that working with sprays may produce vapours which can damage your health (see information on the safety data sheet and the tins of material). You must therefore use a personal breathing equipment, as indicated by the spray material manufacturer. Keep children and all people right away from the work area.
8. Keep the BINKS airless pump in a safe place to which children and unauthorised persons do not have access. Make sure that unauthorised personnel (and children in particular) cannot start up the BINKS airless pump.
9. Store the BINKS airless pump in a dry place.
10. Use only original BINKS accessories and original BINKS replacement parts.
11. **Repair work must only be carried out by authorised specialised companies or by ITW. You can obtain the addresses of specialised companies from ITW or from your specialised dealer**
12. When repairing and mounting the pump it is necessary that all connections are clean and mounted correctly.
Before re-starting the pump the correct resistance (1 M Ω) must be measured.
The resistance has to be determined between foot valve and upper top point of the pump.
13. **You must be careful when carrying out spraying work, not to direct the jet towards the BINKS airless pump unit.**
14. Dispose of cleaning and spraying material waste in accordance with the information provided by the respective spray material and solvent manufacturers.
15. If work is interrupted, to change the nozzle, for example, lock the safety lever on the airless gun. Release pressure from the system.

4.3 PARTICULAR DANGER SPOTS

1. The flow of material escaping from the airless gun is under great pressure and thus has a powerful cutting effect.



You must therefore **never** point the airless gun at yourself or any other person, animal or plant. **Never** touch the spray jet with your fingers or hand, or hold them in front of the airless gun.

Note:

If the cutting effect of the flow of material causes injury **seek medical advice immediately**. Tell the doctor which spray material (paint) and/or solvent (thinners) was involved and provide the relevant information from the manufacturer as per the safety data sheet (supplier, his phone number, the material number).

2. The escaping spray material generates recoil power. You must therefore always hold the airless gun securely and make sure that you have a well-balanced stance.
3. In enclosed systems, or systems which are under pressure, where aluminium or galvanised parts come into contact with the liquid, there can be dangerous chemical reactions if 1.1.1 trichloroethane, methylene chloride or other solvents containing halogenated chlorinated hydrocarbons, are used.

If you use the named solvents or paints which contain these solvents, we recommend that you contact the spray material manufacturer or ITW Oberflächentechnik.

4. If there are malfunctions or obstructions, you must immediately shut off the compressed air supply at the ball valve. Disconnect the unit from the compressed air system, operate the airless gun and open the high pressure filter relief valve before removing the airless gun or the hose.
5. To prevent static charging from causing a fire or an explosion, the equipment must be properly grounded (the pump, the material tank, the object to be coated). If using materials with a flash point under 21 °C of ignition group G1-G3, there must be an additional conductive connection between the material tank and the pump (potential equalisation cable). The material tank must always be made of metal.
6. Prevent spray back into a closed tank, as an ignitable gas/air mixture will build up. Take particular care with materials with a flash point less than 21 °C
7. The A-weighted sound level of pumps may exceed 85 dB (A).

Local conditions may dictate a higher noise level, which could cause noise deafness. If this is the situation, operating personnel must be protected by suitable protective equipment or safety measures.

5. START-UP AND OPERATION

5.1 GROUNDING THE BINKS AIRLESS PUMP



To prevent static charging igniting the flammable spray material, the BINKS airless pump must be grounded in accordance with professional association regulation ZH 1/200 (Germany), "Static Electricity", before it is started up. A grounding cable is included in the supply schedule.

1. Grounding wire has to be mounted on the grounding terminal of the high pressure filter or (if pump is used without HP-filter) on the middle section of the pump.
2. Connect the other end of the grounding cable to a suitable grounding device (e.g. grounding bar).

5.2 PREPARING TO START UP THE BINKS AIRLESS PUMP

Proceed as follows:

1. Check that the lubrication chamber is full. To do this, open the screw plug on the filler neck of the lubrication chamber. If necessary, top up the lubricant (Order Code for solvent paint: 0114-009433, for waterborne paint: 0114-014871) and close the screw plug again.
2. Select a suitable filter cartridge using the table in section 2, Brief Description and insert it into to the high pressure filter.
3. Attach a suitable hose to the spray material line to the spray material outlet connection piece on the high pressure filter.



The spray material lines in the BINKS supply programme are identified on the screw fitting with the maximum permitted working pressure and the bursting pressure. The lesser value, the maximum permitted working pressure, must be greater than the maximum permitted working pressure of the spray material pump (see 3, Technical Data).

4. Connect the airless gun designed at least for the maximum permitted working pressure of the spray material pump, to material pump, to the fluid hose.

We recommend for Airless: BINKS Airless spray gun HAP 50 with max. pressure 500 bar or BINKS Airless spray gun Airless 1 with max. pressure 420 bar.

We recommend for Aircombi: BINKS Aircombi spray gun AA 4000 with max. pressure 275 bar

5. Make sure that the ball valve on the pneumatic drive is closed.
6. Connect the compressed air supply at the compressed air supply connection piece.
7. The airless pump is equipped with an air maintenance unit, consisting of filter, pressure regulator and fog lubricator. The air maintenance unit is intended for cleaning compressed air for workshop purposes from liquid and solid contamination, for pressure regulation and for providing a fine oil spray for lubrication of cylinders, valves etc.

Set the amount of oil (drops per minute) on the dosing screw as required during operation. The number of drops can be seen in the sight-glass.

The filter cleans the compressed air from water condensate, scale, rust particles etc.
Drain off the water condensate at regular intervals and clean the sintered filter if it is dirty.

Before putting the pressure line into operation, relieve the filter regulator by fully unscrewing the regulating screw. Thereafter rotate the regulating screw clockwise until the pressure gauge on the filter regulator indicates the required pressure (please consider the min. and the max. data - see section 3 Technical Data).

5.3 RINSING THE BINKS AIRLESS PUMP



Wear eye protection

Every BINKS airless pump is tested with water during final inspection and thoroughly rinsed with a non-gumming preservative oil. With this rinsing process, it is possible that the residual moisture of water emulsion will be left in the pump.

Before the unit is started up for the first time, a suitable solvent must be used to thoroughly rinse out the remains of the preservative fluid and the unavoidable impurities introduced during equipment assembly.

Proceed as follows:

1. Prepare the BINKS airless pump for start-up in accordance with section 5.2.
2. Close the high pressure filter relief valve.
3. Immerse the spray material pump or the suction system in the tank of solvent.
4. Insert the high pressure filter return pipe into the tank of solvent. Open the high pressure filter relief valve.
5. Open the ball valve of the air supply and set the compressed air control valve on the pressure regulator to approximately 1 bar. The spray material pump or the suction system now draws in the solvent. The solvent runs back to the tank through the high pressure filter, the high pressure filter relief valve and the return pipe.
6. Point the airless gun into the tank. Unlock the safety lever on the airless gun, operate the airless gun trigger and close the high pressure relief valve. The solvent will now flow through the high pressure filter, the spray material line and the airless gun, back into the tank.
The time of rinsing depends on the length of the material lines and the solubility of the spray material. We recommend a short reflush with "fresh" solvent.
7. Release the airless gun take-off.
8. Slowly increase the pressure at the compressed air control valve of the pressure reducer to maximum working pressure (see section 3, Technical Data), while checking and testing that all lines and screw and plug caps are tightly sealed. If there are any leaks in the system, shut down the BINKS airless pump immediately. Only re-start the BINKS airless pump once you have repaired the leak.
9. Reduce the pressure at the compressed air control valve of the pressure reducer again and close the ball valve.

10. Make sure that the return pipe is still directed into the solvent tank. Carefully open the high pressure filter relief valve to reduce the pressure in the spray material pump and in the high pressure filter.
11. Point the airless gun into the tank of solvent and operate the trigger to reduce any pressure which may still exist in the spray material line and in the airless gun.



If working with waterborne spray material, the BINKS airless pump must again be thoroughly rinsed with water before it is started up.

5.4 PREPARING AND ADJUSTING THE SPRAY MATERIAL

To be able to work without trouble and obtain a perfect surface, special care must be taken in preparing and adjusting the lacquers and paints (please contact spray material manufacturer).

Before starting to spray, it may be necessary to use the solvent prescribed by the manufacturer to thin the spray material. Add thinners until, after a good stir, the spray material runs easily off the stick used for stirring. To prevent any uncertainty, we recommend that you use a dip measuring cup, where the run-out time of the spray material indicates whether the spray material is still too thick and therefore whether it is necessary to add more thinners. According to experience, the flow time for lacquers and paints is 18 to 22 DIN4 sec. and for effect lacquer and coating filler materials 25 to 50 DIN4 sec. These figures relating to DIN EN ISO 2431 and have been established at a temperature of 20°C. The lacquer and paint manufacturers generally state the best spraying consistency for each of their products. If you use motor driven mixers, you must ensure that no air bubbles form in the spray material.

To take a measurement, proceed as follows:

Immerse the measuring cup into the lacquer or paint which is ready for spraying until it is full to the brim. To make the measurement, quickly take out the dip measuring cup and count how many seconds it takes for the entire contents of the cup to run through the 4mm nozzle, i.e. up to the time when you can establish the break-off point of the out-flowing paint. Count off the seconds on a wristwatch, or time with a stopwatch. If, for example, a consistency of 19 DIN4 sec. is prescribed, but the measurement is 24 DIN4 sec., you must add some more thinners and make the measurement again.

We recommend that once you have used it, you clean the dip measuring cup immediately, so that it can be used again for the next measurement.

Because two filters are used in the BINKS airless unit, a suction filter and the high pressure filter, it is not necessary to filter the spray material before working with it.

If particularly high-quality coating work is involved, you can also use a gun filter from the BINKS accessories range.

5.5 START-UP

1. Prepare the BINKS airless pump for start-up in accordance with section 5.2 and if necessary, rinse in accordance with section 5.3.

2. Close the high pressure filter relief valve.
3. Immerse the spray material pump or the suction system in the spray material to be used for working.
4. Place the high pressure filter return pipe in the tank. Then open the high pressure filter relief valve.
5. Open the ball valve for the compressed air supply and use the pressure regulator to set the compressed air supply to 1 bar. The material spray pump will now draw in the spray material. The spray material flows back into the tank through the high pressure filter, the high pressure filter relief valve and the return pipe.
6. Point the airless gun into the tank. Unlock the safety lever on the airless gun. Operate the airless gun take-off and close the high pressure relief valve. The spray material will now flow through the high pressure filter, the spray material line and the airless gun, back into the tank.
7. Release the airless gun take-off and set the working pressure at the pressure control valve of the pressure reducer.³

Before carrying out any coating work, we recommend a test spray (e.g. on to paper or wood). Only if the test gives you the desired result should you start to coat the actual object.

Make sure that the edges and the fringe areas of the object to be coated are also given an even coating.

5.6 WORK STOPPAGES



- If working with 2-K spray material, you must note the given pot life and follow it precisely. Within this time, the unit must be carefully cleaned and rinsed with the recommended solvent. There must be no residue left in the spray material pump, the high pressure filters or the airless gun.
- When work is stopped, the safety lever of the airless gun must be locked.

For work stoppages of between 10 and 30 minutes, please proceed as follows:



Wear eye protection

1. Lock the safety lever on the airless gun.
2. Shut off the compressed air supply by closing the ball valve.
3. Briefly open the high pressure relief valve, taking care that the return pipe is not pointed at other people or at yourself, until the pressure has reduced. Then close the high pressure relief valve again.
4. Clean the outside of the airless nozzle from spray material residue.

6. SHUT-DOWN



Once work is completed, the BINKS airless unit must be thoroughly cleaned. Under no circumstances must you allow paint residue to dry out in the unit. To clean the airless unit, use a solvent appropriate to the spray material.



Wear eye protection

1. Close the ball valve for the compressed air supply.
2. Make sure that the return pipe is still directed into the spray material tank. Carefully open the high pressure filter relief valve to reduce the pressure in the spray material pump and in the high pressure filter.
3. Point the airless gun into the tank of spray material and operate the take-off to reduce any pressure which may still exist in the spray material line and in the airless gun.
4. Lock the safety lever on the airless gun.
5. Remove the spray material pump or suction system from the spray material.

7. CLEANING YOUR BINKS UNIT



In no case spray material or solvent should soak into the ground or the canalisation.



Wear eye protection

1. Clean the pump and the suction system from the outside. Immerse the spray material pump or the suction system in the tank of solvent.
2. Clean the fluid tip / tip system as described in the service bulletin of the spray gun. We recommend to stock the fluid tip in solvent.
3. Unlock the safety lever of the airless gun without fluid tip but with mounted tip system or tip guard. Operate the gun. Close the high pressure filter relief valve. Set the incoming air pressure to max. 2 bars and open slowly the ball valve. Let the solvent runs through the system so that the spraying material could rinse out.
4. Let the solvent runs through the system for a couple of minutes until the solvent runs clear through the airless gun. Close the ball valve and lock the safety lever of the gun
5. Clean the airless gun from the outside and check the filter on the handle (if mounted).
6. Clean the filter insert of the high pressure filter.
7. Clean the filter of the suction pipe.
8. We recommend to remain the equipment filled with liquid.

We recommend to preserve the BINKS airless equipment if it is not used for a longer period of time. Please rinse the complete system with silicon-free oil as described in section 5.3.

8. MALFUNCTIONS, POSSIBLE CAUSES AND REMEDIAL MEASURES

In case of a break down of your equipment please contact your dealer or the manufacturer of the unit who will lead a professional repair.

8.1 COMPRESSED AIR SUPPLY UNIT

| Type of defect | Appearance of defect | Possible cause | Remedy |
|-------------------------------------|------------------------------------|--|--|
| No flow through BINKS airless pump. | Spray material pressure drops. | No compressed air. | Check compressed air supply. |
| | BINKS airless pump does not start. | Nozzle on airless gun blocked. | Clean or replace nozzle. |
| Reduction of area. | | Pipeline kinked, pressure controller contaminated. | Check lines. Clean pressure control valve. |
| | | Air motor controller blocked. | Contaminated compressed air. Filter compressed air. |

8.2 PNEUMATIC DRIVE AND CONTROL SYSTEM UNIT

| Type of defect | Appearance of defect | Possible cause | Remedy |
|--|----------------------|---|--|
| Erratic operation, number of strokes reduced, pneumatic drive stops. | Faulty piston valve. | Wear. | Replace parts. |
| | | Foreign matter in the control system. | Remove foreign matter, replace faulty parts. |
| Pneumatic drive frozen up. | | Compressed air too damp. Condensation in the compressed air supply. Too many strokes. | Install water separator. Check compressor. Use smaller spray nozzle. Modify working conditions. Install oiler. Reduce air pressure. |

8.3 SPRAY MATERIAL PUMP UNIT

| Type of defect | Appearance of defect | Possible cause | Remedy |
|--|---|--|---|
| Material coming from the spray material chamber. | | Upper packing of spray material pump faulty. | Replace spray material pump packing. |
| BINKS airless pump runs non-stop. | BINKS airless pump runs on despite stopping spraying. | Lower packing of spray material pump faulty | Replace spray material packing. |
| BINKS airless pump does not stop on down-stroke. | Foot valve or plunger valve faulty or stuck. | Wear. Dried material. | Replace parts. Careful cleaning necessary. |
| BINKS airless pump does not stop on up-stroke. | Foot valve or plunger valve faulty or stuck. | Wear. Dried material. | Replace parts. Careful cleaning necessary. |
| Spray material escape at double piston. | Grooving in the slide faces. | Wear. | Replace parts. |

8.4 SUCTION SYSTEM UNIT

| Type of defect | Appearance of defect | Possible cause | Remedy |
|--|-------------------------|--|----------------------------------|
| BINKS airless pump works erratically. | Suction screen blocked. | Spray material contaminated. | Clean or replace suction screen. |
| BINKS airless pump runs, but there is no flow. | No suction power. | Suction filter dirty. Foot valve ball sticks to valve seat. Suction system not properly screwed down. Spray material pump draws air, screw down properly. | Clean. Make practicable. |

9. INSTRUCTION MANUAL

Depending on the type of application and the place of installation, the operator must use the operating instructions to provide more details on the safe operation of the BINKS airless pump, in the form of an instruction manual in the language of the workforce. This instruction manual is to be kept in a suitable location at the place of work and the workforce informed of its whereabouts. The workforce should comply with the instructions contained in this instruction manual.

10. COMPULSORY TESTING

In accordance with the professional association directives governing spray equipment, ZH 1/406, paint spraying equipment should be checked by an **expert** on request, or at least every 12 months, to ensure that there is no risk involved in its continued operation. If the units are idle, the examination can be delayed until the next period of operation. The operator is obliged to register the equipment for testing and to keep written records of the results of such testing.

An **expert** is someone whose professional training and experience has given him adequate knowledge and understanding of jet stream units and who is sufficiently acquainted with the relevant national health and safety and work and accident prevention regulations, directives and generally recognised technical regulations, that he is able to assess whether jet stream units are safe to operate.

The employer (operator) must make sure that **test results** for each jet stream unit are kept as a **written record** and that this is retained until the next test. We provide a blank "Test record for spraying equipment" form for this purpose. Please make as many copies of this as you need.

Furthermore, you must ensure that this test document is available at the place where the jet stream unit is in use. A copy of the test record or a test plaque is sufficient for this.

But we also ask you to enter the test document, date and expert in the "Test Document" table.

11. TEST DOCUMENTS

Test record for spraying equipment

| | | | | |
|---|---|------------------------------------|-----------------|---------------------------------------|
|  | ITW Oberflächentechnik GmbH & Co. KG Justus-von-Liebig-Straße 31 D-63128 Dietzenbach Telefon +49 (0) 6074 / 403-1 Telefax +49 (0) 6074 / 403-281 | | | Date: |
| | | | | Examiner: |
| DEALER STAMP: | | ADDRESS OF OPERATOR: | | |
| | | Name: | | |
| | | Street: | | |
| | | Postcode/Town: | | |
| | | Contact:.....Phone: | | |
| Tested unit: | | | | |
| Manufacturer: | | Eqpt.-No.: | | |
| Type: | | Year of manufacture: | | |
| <u>System components used:</u> | | | | |
| <input type="checkbox"/> Airless pump | | <input type="checkbox"/> Pump head | | <input type="checkbox"/> Cart |
| <input type="checkbox"/> Airless gun | | | | <input type="checkbox"/> Tripod |
| <input type="checkbox"/> Spray material line | | | | <input type="checkbox"/> Wall bracket |
| Tested components | complies | not tested | does not comply | retrofit recom- mended |
| General condition of system | | | | |
| <u>Jet stream unit</u> | | | | |
| Equipment name plate | | | | |
| Safety valve | | | | |
| Pressure gauge fitting | | | | |
| Pressure relief valve | | | | |
| <u>Jet stream unit with heater</u> | | | | |
| Temperature limitation / control | | | | |
| Temperature display | | | | |
| <u>Spraying device</u> | | | | |
| Max. pressure identification | | | | |
| Equipment number identification | | | | |
| Efficiency | | | | |
| Safety equipment | | | | |
| <u>Hoses and fittings</u> | | | | |
| Hose identification | | | | |
| Fitting identification | | | | |
| <u>Grounding</u> | | | | |
| Between components | | | | |
| Overall system | | | | |
| <u>Measuring of resistance (1 MΩ)</u> | | | | |
| <u>Operating instructions</u> | | | | |
| <u>Function of the overall system</u> | | | | |
| <u>User instructions</u> | | | | |
| Technical condition | | | | |
| Safe condition | | | | |
| Health and safety at work regulations | | | | |
| <u>Overall assessment of the examination</u> | | | | |
| Comments: | | | | |

Ersatzteilliste / spare parts list

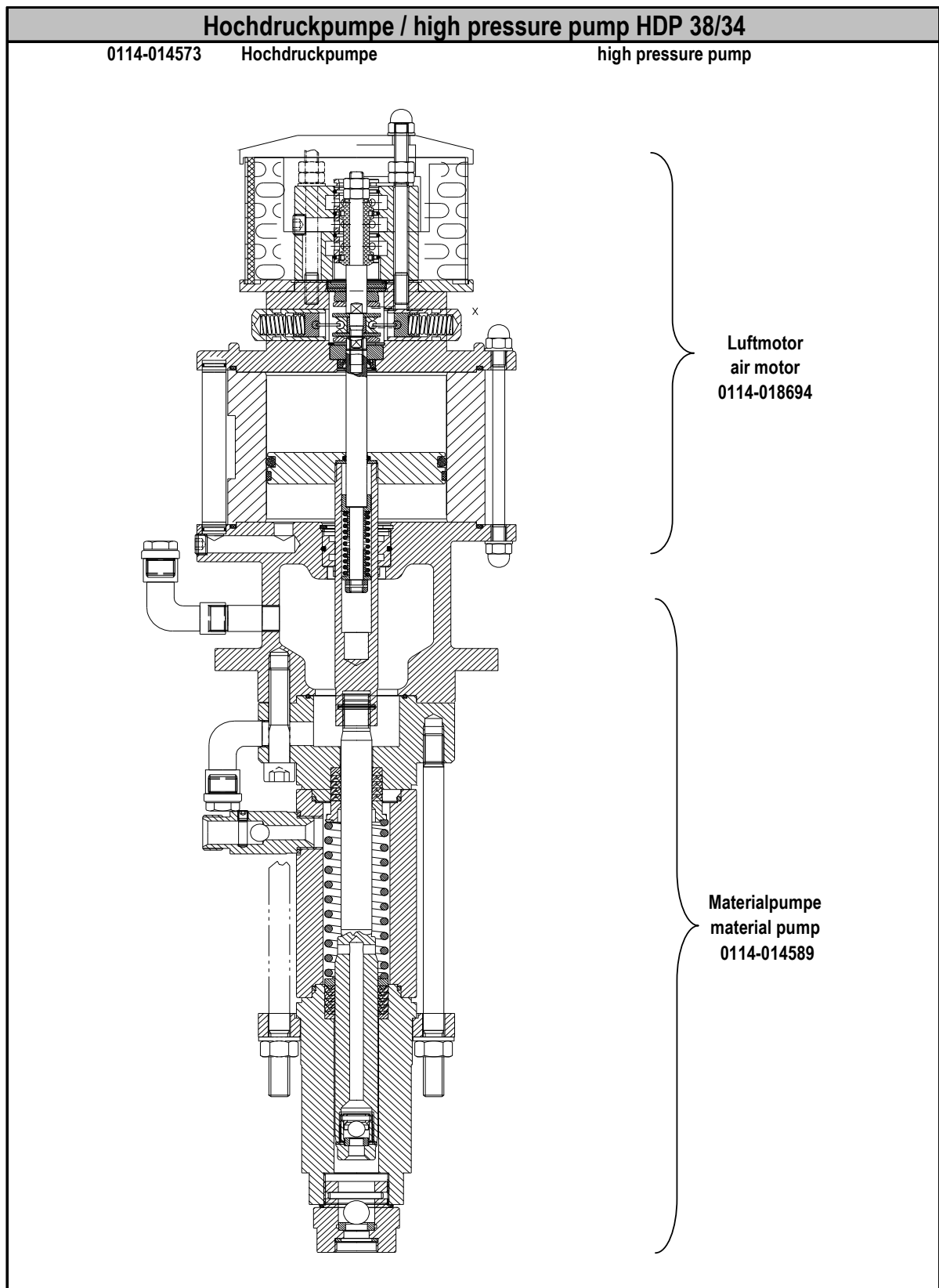

Luftmotor / air motor LM 105/75

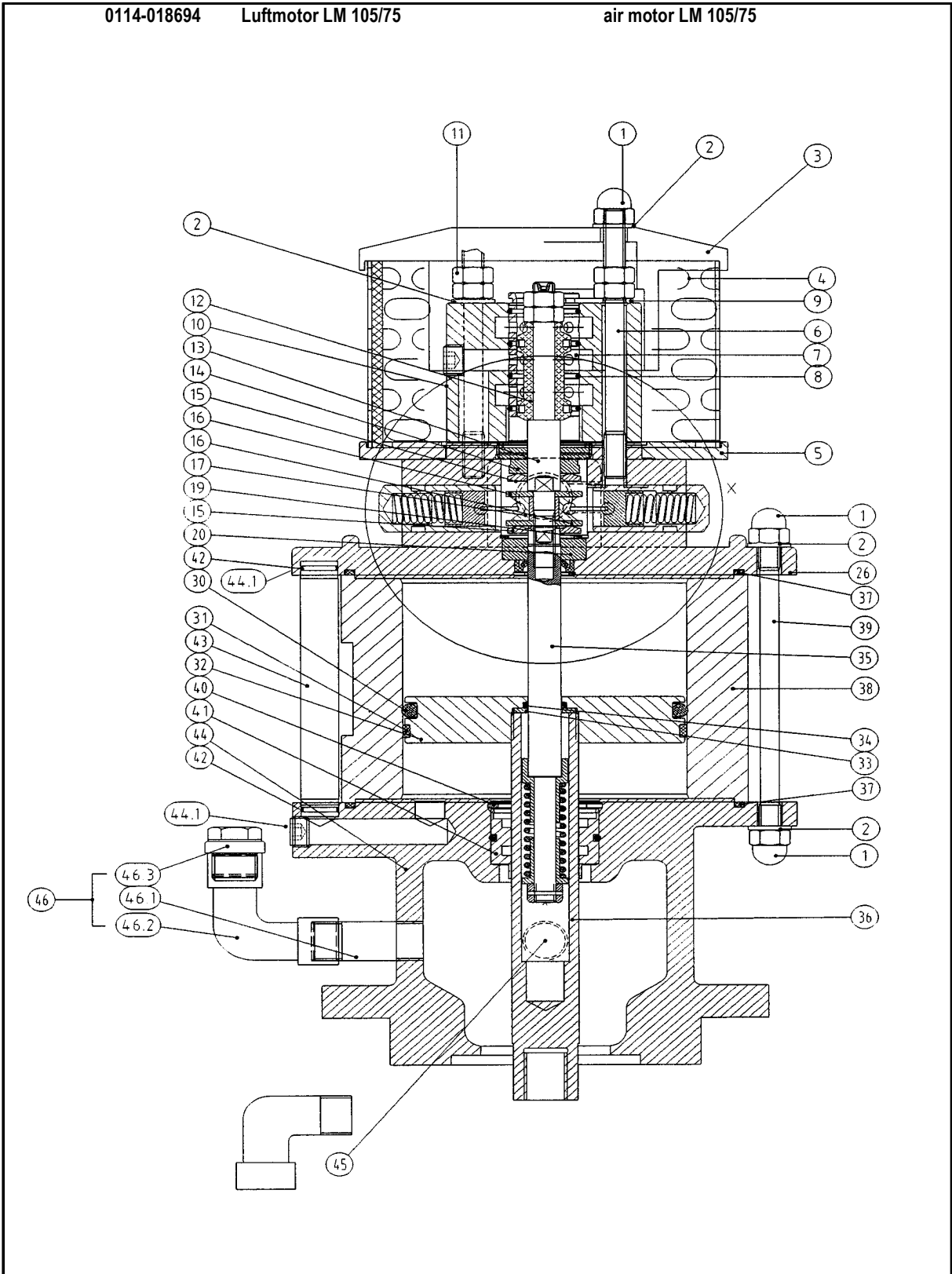

Luftmotor / air motor LM 105/75

0114-018694

Luftmotor LM 105/75

air motor LM 105/75

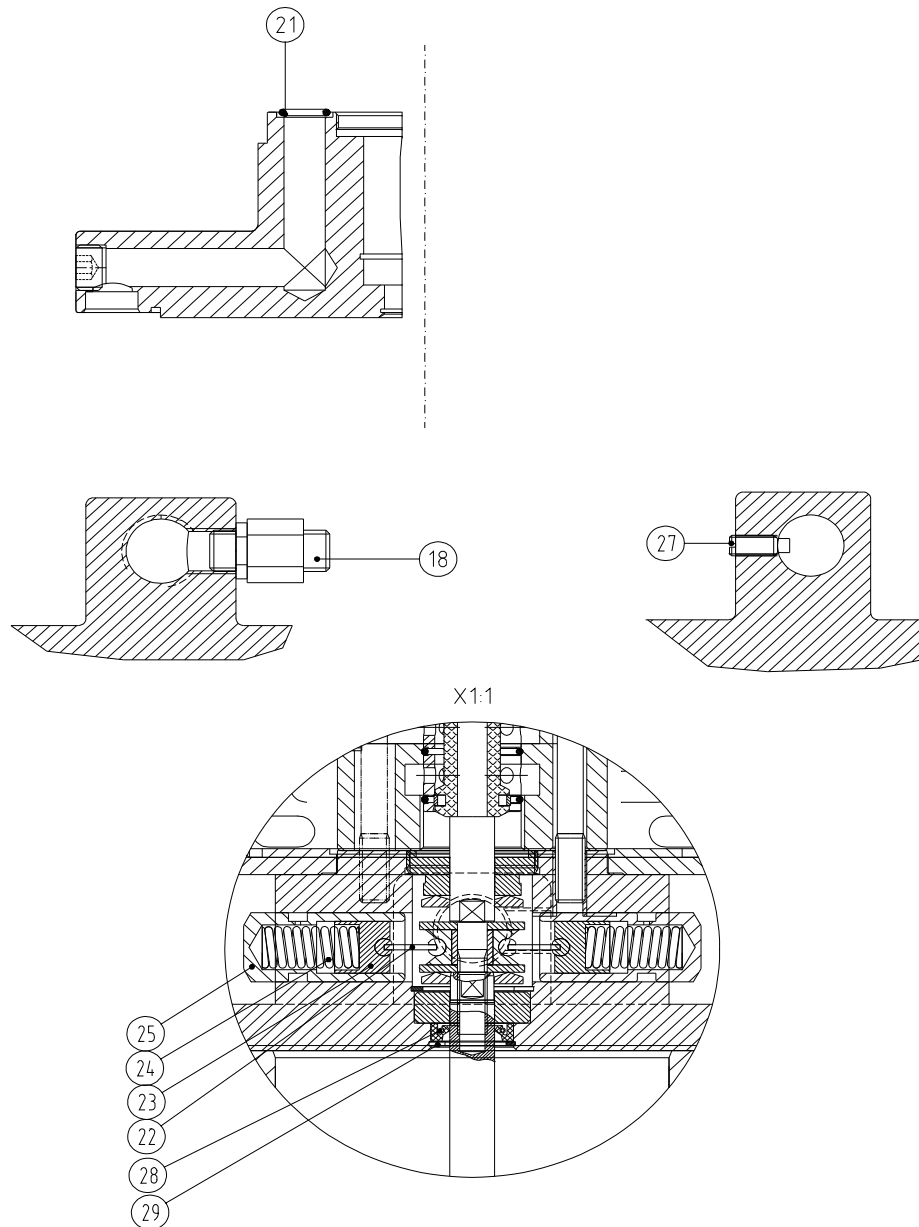

Ersatzteilliste / spare parts list

Luftmotor / air motor LM 105/75

| Pos. | Art.-Nr. | Bezeichnung | Description | | Stück Pcs. | D / R |
|------|--------------------|----------------------------|----------------------------|---|---------------|-------|
| | 0114-018694 | Luftmotor LM 105/75 | air motor LM 105/75 | | | |
| 1 | 0114-014387 | Hutmutter | dome nut | | 11 | |
| 2 | 0114-014165 | U-Scheibe | washer | | 13 | |
| 3 | 0114-014371 | Deckel | cover ass. | | 1 | |
| 4 | 0114-014673 | Schalldämpfer kpl. | air muffler cpl. | | 1 | |
| 5 | 0114-014374 | Scheibe | spacer | | 1 | |
| 6 | 0114-014666 | Stehbolzen | threaded bolt ass. | | 3 | |
| 7 | 0114-014373 | Steuerzylinder | control cylinder | | 1 | |
| 8 | 0114-013954 | O-Ring | o-ring | V | 4 | D / R |
| 9 | 0114-014372 | Sicherungsblech | safety plate | | 1 | |
| 10 | 0114-014656 | Steuergehäuse kpl. | control housing | | 1 | |
| 11 | 0114-014164 | Mutter | nut | | 2 | |
| 12 | 0114-014388 | Steuerkolben kpl. | control piston | V | 1 | R |
| 13 | 0114-014376 | Steuerachse | control axle | V | 1 | |
| 14 | 0114-014379 | Zentrierstück | alignment insert | | 1 | |
| 15 | 0114-014378 | Dämpfungsscheibe | dampening spacer | | 2 | R |
| 16 | 0114-014628 | Scheibe | spacer | | 1 | |
| 17 | 0114-014438 | Mitnehmer kpl. | carrier ass. | V | 1 | |
| 18 | 0114-014774 | Sicherheitsventil 8 bar | safety valve 8 bar | | 1 | |
| 19 | 0114-014619 | Sicherungsring | retaining ring | | 1 | R |
| 20 | 0114-014618 | Scheibe | spacer | | 1 | R |
| 21 | 0114-014608 | O-Ring | o-ring | | 3 | D / R |
| 22 | 0114-014305 | Schnepfer | toggle | V | 2 | |
| 23 | 0114-014340 | Schnepferlager | toggle bearing | V | 2 | |
| 24 | 0114-014067 | Druckfeder | spring | V | 2 | |
| 25 | 0114-014381 | Lagerbuchse | bearing bush | | 2 | |
| 26 | 0114-014661 | Oberteil kpl. neu | cylinder head cpl. New | | 1 | |
| 27 | 0114-014367 | Gewindestift | threaded pin | | 2 | |
| 28 | 0114-014380 | Nutring | u-seal | V | 1 | D / R |
| 29 | 0114-014212 | Sicherungsring | retaining ring | | 1 | D / R |
| 30 | 0114-013989 | O-Ring | o-ring | V | 1 | D / R |
| 31 | 0114-014392 | Führungsring | guide ring | | 1 | D / R |
| 32 | 0114-014391 | Kolbenplatte | piston plate | | 1 | |
| 33 | 0114-014384 | Scheibe | spacer | | 1 | |
| 34 | 0114-014421 | O-Ring | o-ring | V | 1 | D / R |
| 35 | 0114-014396 | Umsteuerachse kpl. | guide axle cpl. | V | 1 | |
| 36 | 0114-014395 | Motorachse | motor axle | V | 1 | |
| 37 | 0114-013993 | O-Ring | o-ring | V | 2 | D / R |
| 38 | 0114-018476 | Zylinder | cylinder | | 1 | |
| 39 | 0114-014386 | Stehbolzen | threaded bolt | | 4 | |
| 40 | 0114-014359 | Sicherungsring | retaining ring | | 1 | D / R |

Vorbehaltl. Techn. Änderungen

Ersatzteilliste / spare parts list

Luftmotor / air motor LM 105/75

| Pos. | Art.-Nr. | Bezeichnung | Description | | Stück Pcs. | D / R |
|---|--------------------|-----------------------|---------------------|---|---------------|----------|
| Luftmotor / air motor LM 105/75 Seite 2 | | | | | | |
| 41 | 0114-014464 | Führungsbuchse kpl. | bush ass. | V | 1 | D / R |
| 42 | 0114-013957 | O-Ring | o-ring | V | 2 | D / R |
| 43 | 0114-014403 | Belüftungsrohr | air inlet pipe | | 1 | |
| 44 | 0114-014660 | Unterteil kpl. neu | bottom ass. New | | 1 | |
| 44.1 | 0114-014657 | Verschlusschraube | closing screw | | 2 | |
| 45 | 0114-013679 | Winkel | elbow | | 1 | |
| 46 | 0114-014561 | Einfüllstutzen kpl. | filler neck | | 1 | |
| 46.1 | 0114-013520 | Nippel | nippel | | 1 | |
| 46.2 | 0114-013670 | Winkel | elbow | | 1 | |
| 46.3 | 0114-013671 | Verschlusschraube | closing screw | | 1 | |
| | 0114-018697 | Dichtungssatz | seal kit | | | D |
| | 0114-018698 | Reparatursatz | repair kit | | | R |
| | | Verschleißteil | wearing part | V | | |

Vorbehaltl. Techn. Änderungen

Ersatzteilliste / spare parts list

Materialpumpe / material pump MP 38/75

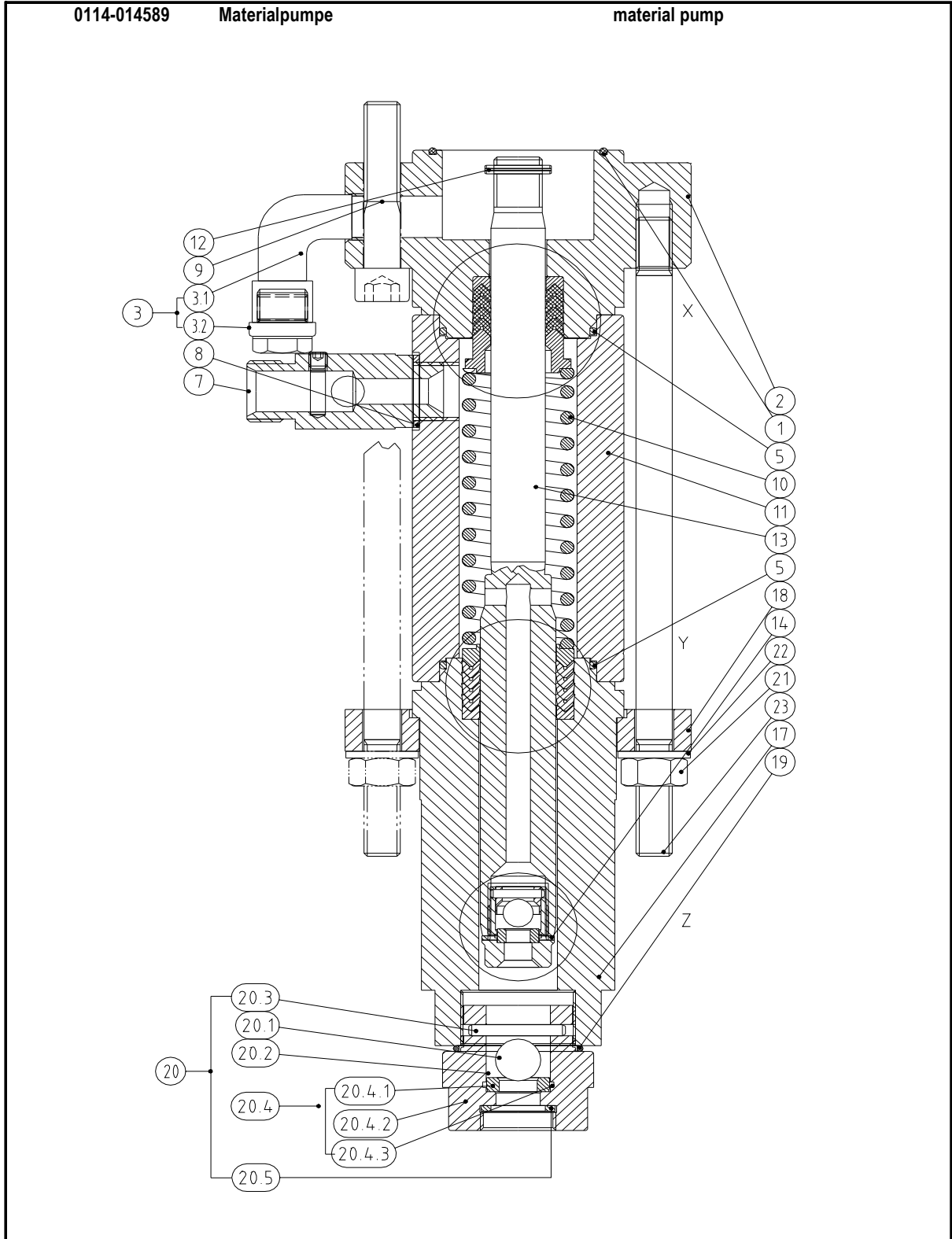

Ersatzteilliste / spare parts list

Materialpumpe / material pump MP 38/75

0114-014589

Materialpumpe

material pump

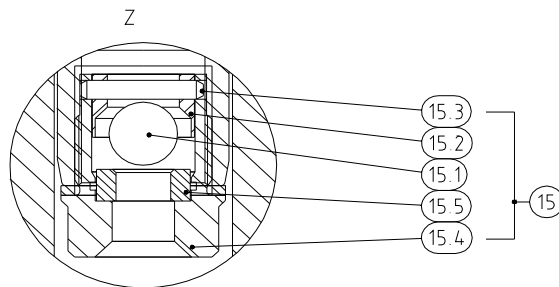
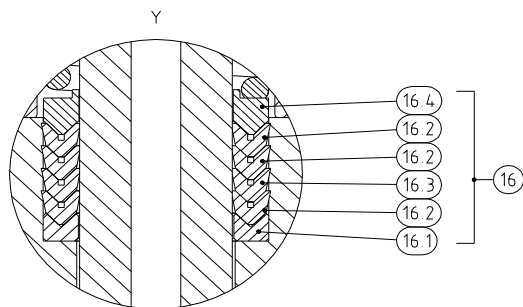
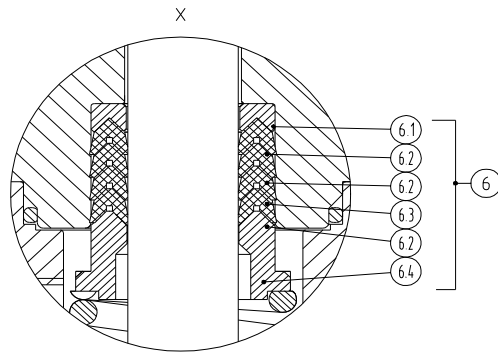

Ersatzteilliste / spare parts list

Materialpumpe / material pump MP 38/75

| Pos. | Art.-Nr. | Bezeichnung | Description | | Stück Pcs. | D / R |
|--------|--------------------|--------------------------------------|-----------------------------------|---|---------------|----------|
| | 0114-014589 | Materialpumpe MP 38/75 | material pump MP 38/75 | | | |
| 1 | 0114-013987 | O-Ring | o-ring | | 1 | D / R |
| 2 | 0114-014587 | Hochdruckkopf | pump head | | 1 | |
| 3 | 0114-019093 | Ablassventil kpl. | outlet valve kpl. | | 1 | |
| 3.1 | 0114-013679 | Winkel | elbow | | 1 | |
| 3.2 | 0114-013671 | Verschlußschraube | lock screw | | 1 | |
| 5 | 0114-014269 | Dichtring | gasket | | 1 | D / R |
| 6 | 0114-014477 | Packung gemischt oben kpl. | packing mixed ass. | V | 1 | R |
| wahlw. | 0114-018924 | Packung PTFE oben kpl. | packing PTFE ass. | V | 1 | R |
| wahlw. | 0114-016285 | Packung hochfest gemischt kpl. oben | upper high-strength packing mixed | V | 1 | |
| wahlw. | 0114-016283 | Packung hochfest kpl. oben | upper high-strength packing cpl. | V | 1 | |
| 7 | 0114-013555 | Rückschlagventil kpl. | non return valve | | 1 | |
| 8 | 0114-014202 | Dichtung | gasket | | 1 | D / R |
| 9 | 0114-014370 | Schraube | screw | | 3 | |
| 10 | 0114-014047 | Druckfeder | spring | V | 1 | |
| 11 | 0114-014585 | Federgehäuse | spring housing | | 1 | |
| 12 | 0114-014159 | Spannhülse | tension pin | | 1 | |
| 13 | 0114-014459 | Doppelkolben | dual piston | V | 1 | |
| 14 | 0114-014012 | Dichtung | gasket | | 1 | D / R |
| 15 | 0114-014627 | Kolbenventil kpl. | valve piston ass. | | 1 | |
| 15.1 | 0114-014022 | Kugel | ball | V | 1 | R |
| 15.2 | 0114-014755 | Kugelführung | ball guide | | 1 | |
| 15.3 | 0114-014159 | Spannhülse | tension pin | | 1 | R |
| 15.4 | 0114-013783 | Ventilgehäuse kpl. | valve housing cpl. | V | 1 | |
| 16 | 0114-014476 | Packung gemischt unten kpl. | packing mixed ass. | V | 1 | R |
| wahlw. | 0114-018925 | Packung PTFE unten kpl. | packing PTFE ass. | V | 1 | R |
| wahlw. | 0114-016286 | Packung hochfest gemischt kpl. unten | lower high-strength packing mixed | V | 1 | |
| wahlw. | 0114-016284 | Packung hochfest kpl. unten | lower high-strength packing cpl. | V | 1 | |
| 17 | 0114-014586 | Druckzylinder | pressure cylinder | | 1 | |
| 18 | 0114-014460 | Anzugring | connecting ring | | 1 | |
| 19 | 0114-013946 | O-Ring | o-ring | | 1 | D / R |
| 20 | 0114-014727 | Bodenventil kpl. | bottom valve ass. | | 1 | |
| 20.1 | 0114-014237 | Kugel | ball | V | 1 | R |
| 20.2 | 0114-014753 | Kugelführung | ball guide | | 1 | |
| 20.3 | 0114-014568 | Zylinderstift | cylindrical pin | | 1 | R |
| 20.4 | 0114-014625 | Bodenventilgehäuse | valve housing | V | 1 | |
| 20.5 | 0114-013834 | Dichtung | gasket | | 1 | D / R |
| 21 | 0114-014415 | Mutter | nut | | 3 | |
| 22 | 0114-014422 | U-Scheibe | washer | | 3 | |
| 23 | 0114-014570 | Stehbolzen | threaded bolt | | 3 | |
| | 0114-014648 | Dichtungssatz | seal kit | | | D |
| | 0114-014754 | Reparatursatz (Packung gem.) | repair kit (packing mixed) | | | R |
| | 0114-016007 | Reparatursatz (Packung PTFE) | repair kit (packing PTFE) | | | R |
| | | Verschleißteil | wearing part | V | | |

Ersatzteilliste / spare parts list

Reparaturset Luftmotor / repair kit air motor LM 105/75

0114-018698

4x
0114-013954
O-Ring
19x1,8mm

1x
0114-014388
Steuerkolben kpl.

2x
0114-014378
Dämpfungsscheibe
27x11,7mm

1x
0114-014619
Si-Ring JV32

1x
0114-014618
Scheibe
31x12x9mm

3x
0114-014608
O-Ring
11x2mm

1x
0114-014380
Nutting
21,8x12,2x5,2mm

1x
0114-014212
Si-Ring JS22

1x
0114-014392
Führungsring
L=32cm

1x
0114-013989
O-Ring 94,2x5,7mm

1x
0114-014421
O-Ring 12,3x2,4mm

2x
0114-013990
O-Ring 105x2 mm
für alte Ausführung
LM 105/75

2x
0114-013993
O-Ring 140x3 mm
für aktuelle Ausführung
LM 105/75

1x
0114-014359
Si-Ring JS40

1x
0114-014464
Führungsbuchse
kpl.

2x
0114-013957
O-Ring 8x1,5mm

Ersatzteilliste / spare parts list

Dichtungssatz Luftmotor / seal kit air motor LM 105/75

0114-018697

4x 
0114-013954
O-Ring
19x1,8mm

3x 
0114-014608
O-Ring
11x2mm

1x 
0114-014380
Nutting
21,8x12,2x5,2mm

1x 
0114-014212
Si-Ring JS22

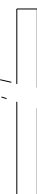
1x 
0114-014392
Führungsring
L=32cm

1x 
0114-014421
O-Ring 12,3x2,4mm

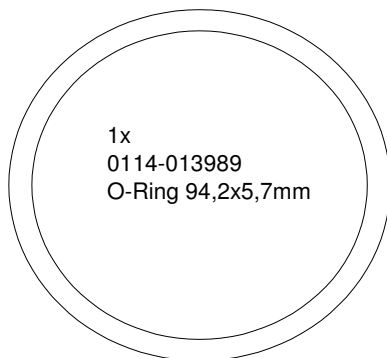

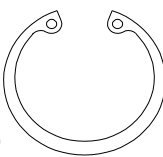
1x 
0114-014359
Si-Ring JS40

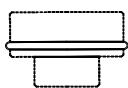
1x 
0114-014464
Führungsbuchse
kpl.

2x 
0114-013957
O-Ring 8x1,5mm



Reparaturatz Materialpumpe MP38/75R
repair kit material pump MP38/75R
0114-014754

Packung gem. Oben
0114-014477



Sattelring
Manschette PTFE
Manschette PTFE
Manschette Leder
Manschette PTFE
Gegenring RF

Packung gem. Unten
0114-014476



Sattelring
Manschette PTFE
Manschette PTFE
Manschette Leder
Manschette PTFE
Gegenring RF



2x
0114-014159
Spannhülse 18x3mm



1x
0114-014568
Zylinderstift 32x4mm



1x
0114-014237
Kugel 15mm



1x
0114-014022
Kugel 10mm



1x
0114-013834
Dichtung 24,5x18x2mm



2x
0114-014269
Dichtring 52x47x2,6



1x
0114-014012
Dichtung 24x20x1,5mm



1x
0114-013946
O-Dichtung 43x39x2mm



1x
0114-014202
CU-Dichtung 26x21x2

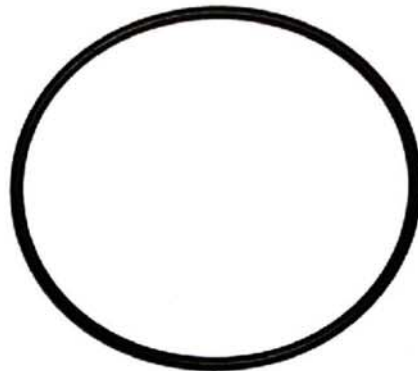

1x
0114-013987
O-Ring 53x2mm

Reparaturset Materialpumpe MP38/75
repair kit material pump MP38/75
0114-016007



Satterring
 Manschette PTFE
 Manschette PTFE
 Manschette PTFE
 Manschette PTFE
 Gegenring RF

Packung PTFE unten 0114-018925



Satterring
 Manschette PTFE
 Manschette PTFE
 Manschette PTFE
 Manschette PTFE
 Gegenring RF

Packung PTFE oben 0114-018924



1x
 0114-014237
 Kugel 15mm



...
 0114-014022
 Kugel 10mm

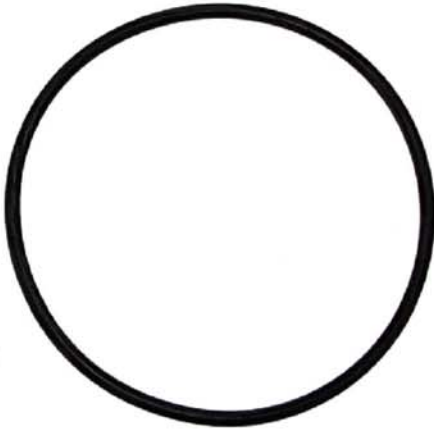

1x
 0114-013987
 O-Ring 53x2mm



2x
 0114-014269
 Dichtring 52x47x2,6



1x
 0114-013946
 O-Dichtung 43x39x2mm



1x
 0114-014012
 Dichtung 24x20x1,5mm



1x
 0114-014202
 CU-Dichtung 26x21x2



1x
 0114-013834
 Dichtung 24,5x18x2mm



2x
 0114-014159
 Spannhülse 18x3mm



1x
 0114-014568
 Zylinderstift 32x4mm

Ersatzteilliste / spare parts list

Dichtungssatz Materialpumpe / seal kit material pump MP 38/75

0114-014648

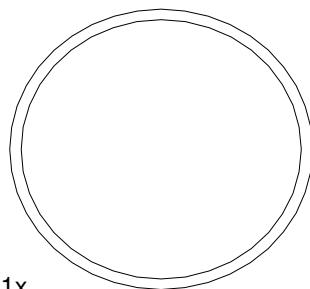

1x
0114-013987
O-Ring 53x2 mm

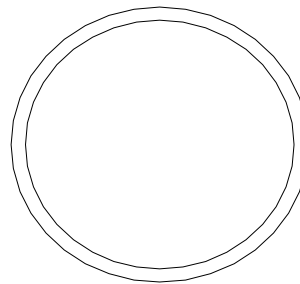

2x
0114-014269
Dichtring 52x47x2,6

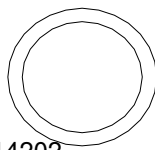

1x
0114-014202
CU-Dichtung 26x21x2

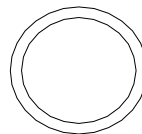

1x
0114-014012
Dichtung 24x20x1,5 mm

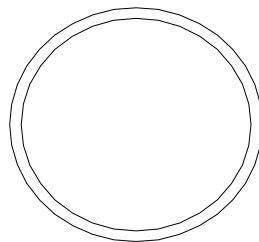

1x
0114-013946
O-Dichtung 43x39x2 mm

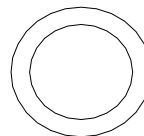

1x
0114-013834
Dichtung 24,5x18x2 mm

Ersatzteilliste / spare parts list

Ersatzteile Fahrgestell / spare parts trolley

| Pos. | Art.-Nr. | Bezeichnung | Stk. pcs. | Description |
|------|--------------------|--------------------------------|--------------|------------------------|
| | 0114-014614 | Fahrgestell Typ 02 | | trolley type 02 |
| 1 | 0114-014640 | Gestell | 1 | frame |
| 2 | 0114-014057 | Rad | 2 | wheel |
| 5 | 0114-014795 | Wandhalter kpl. bestehend aus: | 1 | wall holder cpl. |
| | 0114-019005 | Wandhalter | 1 | wall holder |
| | 0114-014164 | Mutter | 4 | nut |
| | 0114-014165 | U-Scheibe | 4 | washer |
| | 0114-014216 | Schraube | 4 | screw |
| 6 | 0114-014164 | Mutter | 4 | nut |
| 7 | 0114-014165 | U-Scheibe | 4 | washer |
| 8 | 0114-014170 | Schraube | 4 | screw |

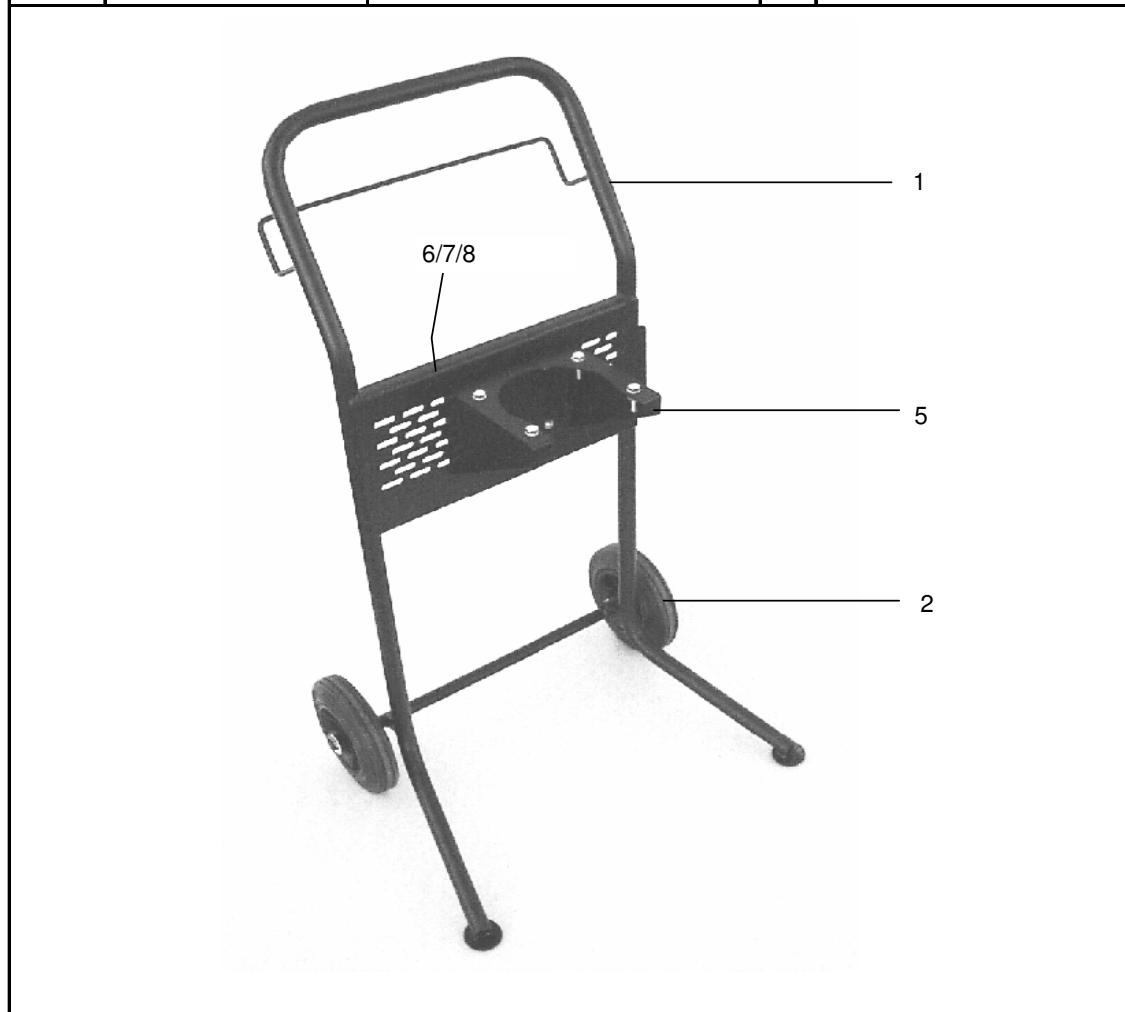

Vorbehaltl. Techn. Änderungen

Ersatzteilliste / spare parts list

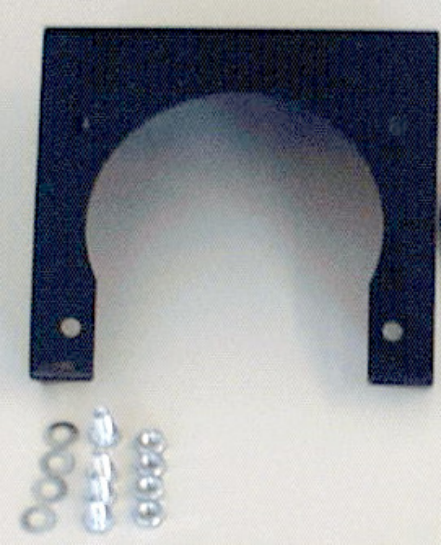
| Ersatzteile Wandhalter / spare parts wall bracket | | | | |
|--|--------------------|--------------------------|--------------|-----------------------------------|
| Pos. | Art.-Nr. | Bezeichnung | Stk. pcs. | Description |
|  | | | | |
| | 0114-014795 | Wandhalter Typ 02 | | wall bracket assy. type 02 |
| | 0114-019005 | Wandhalter | 1 | wall bracket |
| | 0114-014216 | Schraube | 4 | screw |
| | 0114-014165 | U-Scheibe | 4 | washer |
| | 0114-014164 | Skt.Mutter | 4 | nut |

Vorbehaltl. Techn. Änderungen

Ersatzteilliste / Spare parts list

Druckregler / air regulator 3/8"-1/2" Aircombi

0110-011745

Druckregler Aircombi

air pressure regulator Aircombi

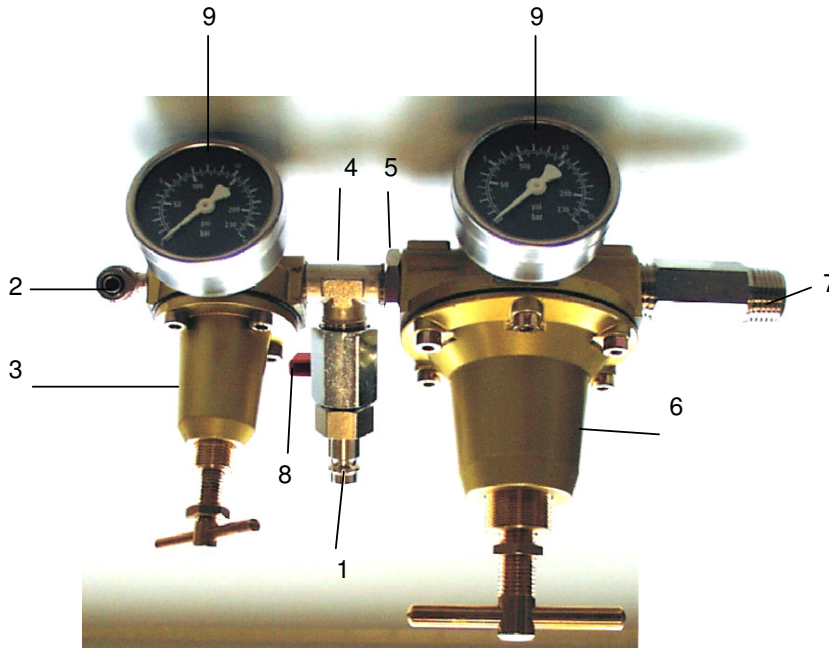

| Pos. | Art.-Nr. | Bezeichnung | Description |
|------|----------------|---------------------|---------------------------|
| 1 | 0114-009048 | Einstecknippel | 1 nipple |
| 2 | 0110-009164 | Winkelverschraubung | 1 fitting |
| 3 | 0114-013531-01 | Druckregler kpl. | 1 pressure regulator cpl. |
| 4 | 0110-009049 | T-Stück | 1 T-piece |
| 5 | 0110-009051 | Reduziernippel | 1 nipple |
| 6 | 0114-020291 | Druckregler kpl. | 1 pressure regulator cpl. |
| 7 | 0114-009266 | Doppelnippel | 1 nipple |
| 8 | 0114-021608 | Kugelhahn | 1 valve |
| 9 | 0114-014048 | Manometer | 2 gauge |

Vorbehaltl. Techn. Änderungen

Ersatzteilliste / Spare parts list

Druckregler / pressure regulator 1/2" Airless

0110-009348

Druckregler

pressure regulator

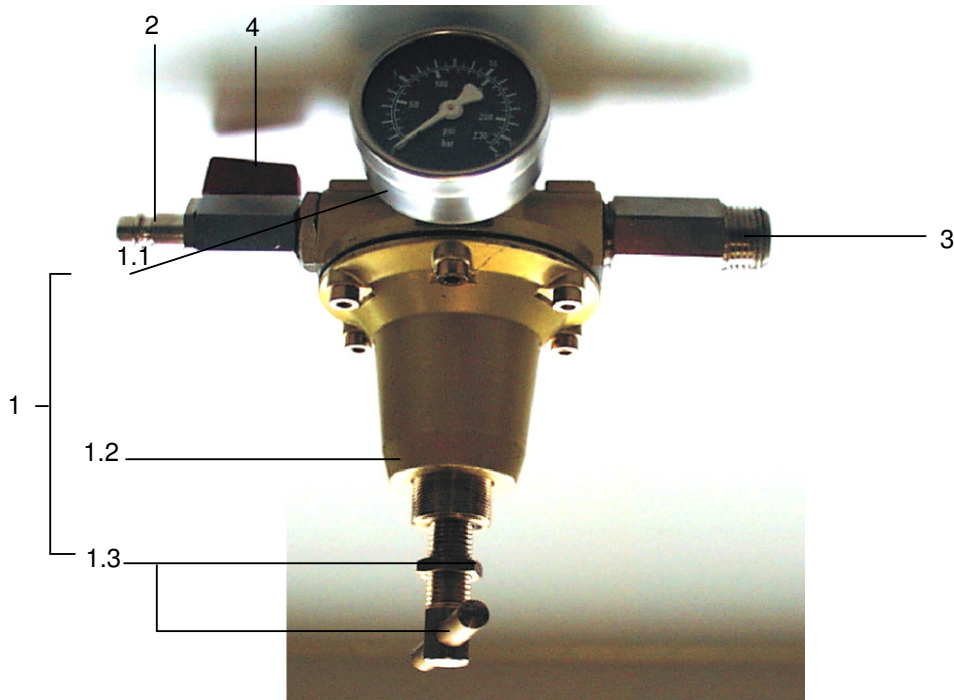

| Pos. | Art.-Nr. neu | Bezeichnung | Stck. Pcs. | Description |
|------|-----------------|---------------------------|---------------|-------------------------|
| 1 | 0114-020291 | Druckregler kpl. | 1 | pressure regulator cpl. |
| 1.1 | 0114-014048 | Manometer | 1 | pressure gauge |
| 1.2 | 0114-019051 | Druckregler | 1 | pressure regulator |
| 1.3 | 0114-014125 | Knebelschraube mit Mutter | 1 | t-handle with nut |
| 2 | 0114-009044 | Einstecknippel | 1 | nipple |
| 3 | 0114-009266 | Doppelnippel | 1 | nipple |
| 4 | 0114-021608 | Kugelhahn | 1 | valve |

Vorbehalt. Techn. Änderungen

Ersatzteile HD-Filter 03 / spare parts HP-filter 03

| Pos. | Art.-Nr. | Bezeichnung | Stück Pcs. | Description |
|------|--------------------|---|------------|---|
| | 0110-009130 | HD-Filter 03 kpl. mit Sieb 100 M | | HP-filter cpl. + filter insert 100 m |
| 1 | 0114-016061 | Dichtung | 1 | gasket |
| 2 | 0114-016060 | Feder für Siebeinsatz klein | 1 | spring for filter insert small |
| 3 | 0110-009131 | Siebeinsatz 50 M, SS | | filter insert 50 mesh, SS |
| | 0110-009132 | Siebeinsatz 100 M, SS * | 1 | filter insert 100 mesh, SS |
| | 0110-009133 | Siebeinsatz 150 M, SS | | filter insert 150 mesh, SS |
| | 0110-009134 | Siebeinsatz 200 M, SS | | filter insert 200 mesh, SS |
| 4 | 0114-014916 | Siebeinsatz klein 30 M, blau | | filter insert small 30 mesh, blue |
| | 0114-014887 | Siebeinsatz klein 50 M, orange | | filter insert small 50 mesh, orange |
| | 0114-014876 | Siebeinsatz klein 70 M, gelb | | filter insert small 70 mesh, yellow |
| | 0114-014875 | Siebeinsatz klein 100 M, schwarz * | 1 | filter insert small 100 mesh, black |
| | 0114-014877 | Siebeinsatz klein 150 M, rot | | filter insert small 150 mesh, red |
| | 0114-014878 | Siebeinsatz klein 200 M, weiss | | filter insert small 200 mesh, white |
| 5 | 0114-016058 | Einlaufverschraubung | 1 | inlet screwing |
| 6 | 0114-016059 | Auslassverschraubung | 1 | outlet screwing |
| 7 | 0110-009065 | Erdungsklemme | 1 | grounding clamp |
| 8 | 0114-019090 | Ablassverschraubung | 1 | outflow screwing |
| 9 | 0114-019091 | Kugelhahn | 1 | ball valve |
| 10 | 0114-019092 | Schlauchnippel | 1 | hose connection |
| 11 | 0110-009103 | Rücklaufschlauch | 1 | return flow hose |

* standard

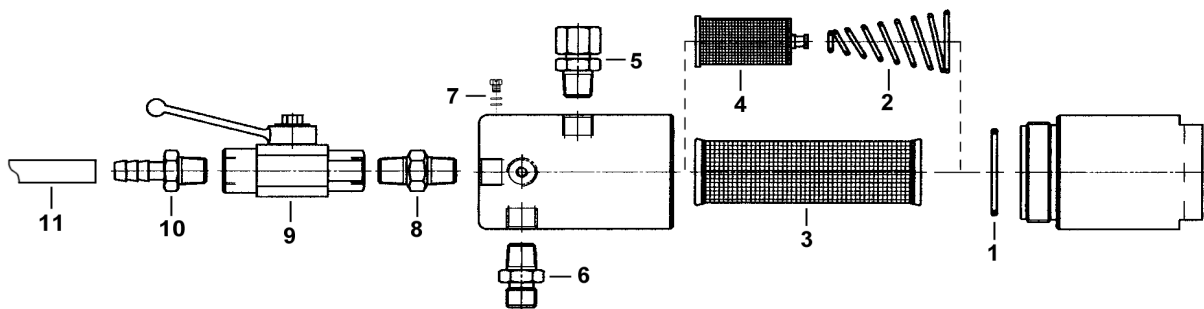

Ersatzteilliste / spare parts list

Ersatzteile Ansaugleitung / spare parts suction system

| Pos. | Art.-Nr. | Bezeichnung | St. Pcs. | Description |
|------|--------------------|------------------------------------|----------|--------------------------------------|
| | 0114-014844 | Ansaugsystem NW 20 flexibel | | suction system DN 20 flexible |
| 1 | 0114-013801 | Reduziernippel | 1 | reducing nipple |
| 2 | 0114-018506 | Ansaugleitung NW 20 | 1 | suction hose DN 20 |
| 3 | 0114-013734 | Siebgehäuse | 1 | filter housing |
| 4 | 0114-014112 | Materialsieb D 70 M 20 | 1 | strainer 20 mesh |
| | 0114-014068 | Materialsieb D 70 M 50 | | strainer 50 mesh |
| | 0114-014221 | Materialsieb D 70 M 70 | | strainer 70 mesh |
| 5 | 0114-014080 | Sicherungsring | 1 | retaining ring |

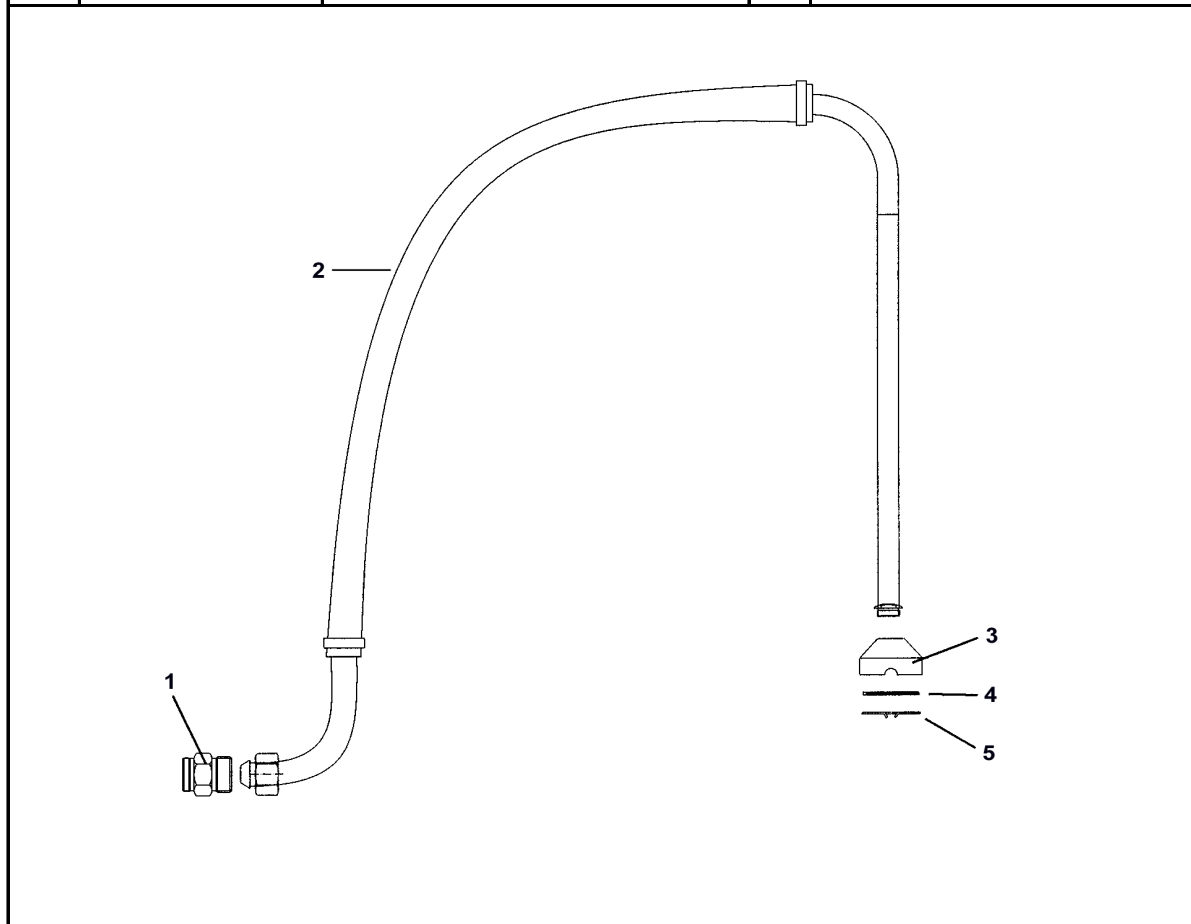

Vorbehaltl. Techn. Änderungen

13. RECOMMENDED GUN

| High Pressure Pump | Max. Pressure Pump (bar) | Recommended Gun | Max. Pressure Gun (bar) |
|-----------------------------|--------------------------|--------------------------------|-------------------------|
| HP 3/28 Airless-Outfit | 224 | HAP 50 Airless 1 | 500 420 |
| HP 3/28 Aircombi-Outfit | 224 | AA 4000 DSG-2000 | 275 250 |
| HP 4/20 Airless-Outfit | 100 | HAP 50 Airless 1 | 500 420 |
| HP 4/20 Aircombi-Outfit | 100 | AA 1500 AA 4000 DSG-2000 | 105 275 250 |
| HP 4/32 Airless-Outfit | 256 | HAP 50 Airless 1 | 500 420 |
| HP 4/32 Aircombi-Outfit | 256 | AA 4000 DSG-2000 | 275 250 |
| HP 6/34 Airless-Outfit | 272 | HAP 50 Airless 1 | 500 420 |
| HP 6/34 Aircombi-Outfit | 272 | AA 4000 | 275 |
| HP 6/60 Airless-Outfit | 390 | HAP 50 Airless 1 | 500 420 |
| HP 10/32 Airless-Outfit | 256 | HAP 50 Airless 1 | 500 420 |
| HP 10/32 Aircombi-Outfit | 256 | AA 4000 | 275 |
| HP 20/66 Airless-Outfit | 429 | HAP 50 | 500 |
| HP 25/48 Airless-Outfit | 384 | HAP 50 Airless 1 | 500 420 |
| HP 30/32 Airless-Outfit | 256 | HAP 50 Airless 1 | 500 420 |
| HP 30/75 Airless-Outfit | 474 | HAP 50 | 500 |

14. EC DECLARATION OF CONFORMITY

ITW Finishing Systems and Products

Ringwood Road,
Bournemouth
BH11 9LH,
England

As the representative/manufacturer of the items listed below:

High-Pressure Paint Pump Models BINKS

**HP 4/20, HP 3/28, HP 4/32, HP 10/32, HP 6/34, HP 25/48, HP 6/60,
HP 20/66, HP 30/32, HP 30/75**

Declare, under our sole responsibility, that the equipment to which this document relates is in conformity with the following standards or other normative documents:

EN 13463 1:2009, EN 13463 5-2005, EN 982 :1996 + A1 :2008 and EN 12621 :2006

And thereby conform to the protection requirements of Council Directive 98/37/EC relating to **Machinery Safety Directive** and council Directive 94/9/EC relating to **Equipment and Protective Systems intended for use in Potentially Explosive Atmospheres;**

CE  2 II Gc T4

Issued on: 23/02/10

Authorised by:



Dave Smith
General Manager

15. WARRANTY STATEMENT

5 – Year HP Piston Pump Warranty

All Piston Pumps are backed by our 5-year warranty, as a measure of the confidence we place in the quality of these products - a confidence that you can share.

BINKS HP Piston Pumps Five-Year Warranty

ITW Finishing Systems and Products (“ITW“) warrants to the original use purchaser of ITW manufactured HP Piston Pumps that ITW will repair or replace, free of charge, including return shipping costs within Europe, any such products which under normal use and service proves defective in material or workmanship, as determined by ITW inspection, within FIVE YEARS from date of shipment from ITW, provided the claimed defective product, or part thereof, is promptly returned to the ITW factory or ITW authorised warranty repair centre with transportation pre-paid.

This warranty does not cover failure of parts or components due to normal wear or damage, which in the judgement of ITW, arises from misuse, abrasion, corrosion, negligence, accident, substitution of non ITW parts, faulty installation or tampering.

If ITW inspection discloses no defect in material or workmanship, repair or replacement and return will not be covered by the ITW warranty.

This warranty covers ITW manufactured Piston Pumps manufactured and shipped on or after January 1st, 2004.

Equipment not covered by this ITW warranty such as accessories or components of equipment (switches, connections, fittings, hoses) which are sold by ITW are subject to the ITW Standard Terms of Sales & Delivery and the terms of the individual manufacturer.

The foregoing warranty supersedes, voids and is lieu of all or any other ITW warranties, express or implied, and no warranty or merchantability or fitness for particular purpose is intended or made. ITW’s sole obligation and the original use purchaser’s sole remedy is as stated above and in no event shall ITW be liable for any special, direct, indirect, incidental, consequential or other damages, or expenses of any nature including, without limitation, loss of profits or production time incurred by the original use purchaser or any other party.

Authorised by:

A handwritten signature in black ink, appearing to read 'D Smith'.

David Smith
General Manager